

Nn3 SOUTHERN PACIFIC NARROW GAUGE LOCOMOTIVE #18

T R Knapp Model Engineering

Originally built by Baldwin in 1911 for the NCO and one of three ten-wheelers acquired by the Southern Pacific in 1928 for use on the ex-Carson & Colorado right-of-way through the Nevada and California desert from Mound House near Carson City, Nevada, to Keeler, California, in the Mojave Desert (the famous "Slim Princess" railroad). Locomotives No. 8 & 9 had Stephen-son valve gear while locomotive No. 18 has Walschaerts valve gear and large air tanks under the cab. It has been restored by the Carson & Colorado Railway volunteer group.



This kit consists of 3D-printed resin parts to convert one Rokuhan Z-scale 4-6-2 (C-57) model to Nn3. The builder will need to provide the C-57, a longer screw for the tender frame extension and screws for attaching the tender shell to the tender frame, a Micro Trains Line 905 Nn3 coupler, Gold Medal Models etched handrail stanchions, brass wire for railings, paint and decals.



The Rokuhan Z-scale 4-6-2 (C-57) is available from several domestic & overseas sources, including:
<https://www.plazajapan.com/>
<https://www.hlj.com/>
<https://www.1999.co.jp/eng/>
<https://ztrackcenter.com/>
<https://www.zscalehobo.com/>
and Amazon Japan.

See review of Rokuhan C57 at:
https://youtu.be/YbM3_MjRDzo?feature=shared

Note: The Rokuhan model has a high starting voltage; it may benefit from re-motoring with a 12VDC motor from Tramfabrik or adding DCC.



To disassemble the C-57, first disconnect the tender from the locomotive: remove the front tender truck, disengage the drawbar, and pull the two apart, pulling the driveshaft free; remove the pilot truck by pulling it forward; remove the drawbar from the locomotive and slide off the trailing truck, then re-install the drawbar. (Continued next page.)



Nn3 Southern Pacific Narrow Gauge Locomotive #18

Carefully pry the sides of the tender shell apart and lift the shell off the tender; similarly pry the sides of the locomotive cab apart and lift it up enough to disengage with the diecast chassis, then pry up on the bottom of the smokebox to free the front of the superstructure molding and lift it off.

Note: The LED light board can be removed. (See optional headlight and loco wiring suggestions.)

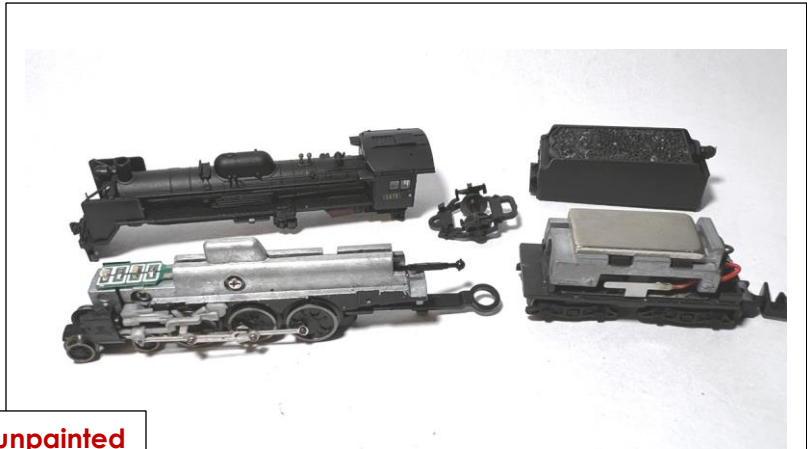

NOTE: The following steps are shown with unpainted 3D printed resin parts for clarity; it is recommended the parts be painted prior to assembly.

Chase holes in the cylinders and pilot 3D print as required with a small drill bit. Remove the screw holding the Rokuhan cylinders to the chassis and install the 3D printed cylinders and pilot, fitting the piston rod and crosshead guide into the holes in the cylinders. (Hint: a drop of Pilobond contact cement on the mating surfaces will prevent the pilot rotating sideways out of alignment.)

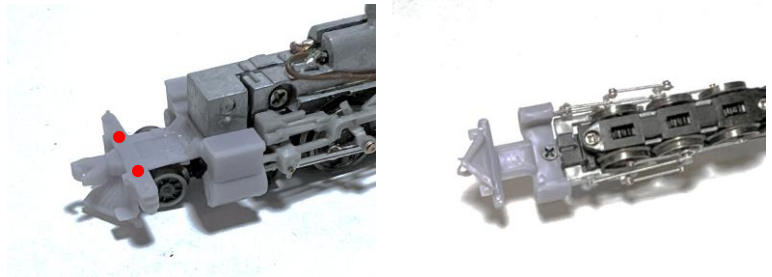

Add smokebox locking tab to front of diecast chassis. Use either a two-part epoxy (taking care not to get it into the mechanism) or drill chassis for screw. Note wiring running to tender added to improve pick-up.

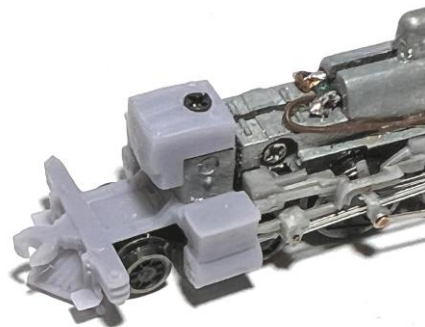

Test fit locomotive superstructure by slipping over the locking tab and chassis and pressing cab end of superstructure down until tabs lock the rear of the superstructure in place. (This is a tight press fit – take care not to break details such as cab roof vent.) When satisfied with fit, remove for detailing and painting taking care not to break the print when spreading the cab floor apart.

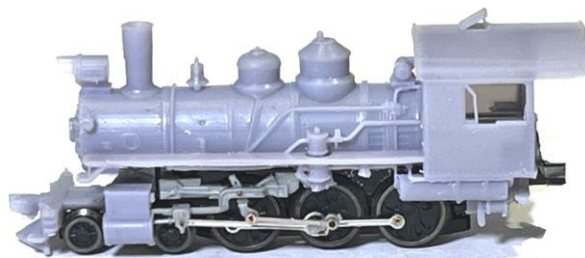

Nn3 Southern Pacific Narrow Gauge Locomotive #18

Remove trucks from tender. File/sand detail off sideframes, and glue 3D printed truck sideframes in place. Solder leads made from small "magnet" wire or surplus wire from pre-wired LEDs to the metal tabs on the rear truck.



Using "rail nippers" or other side cutters, cut rear body bolster off tender floor. Remove screw from rear motor mount and fit tender frame extension using a longer screw. (Collections of tiny metric screws good for this are available on Amazon.)

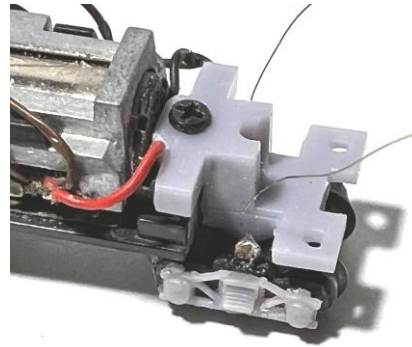

Using a fine tip marking pen, add index marks to bottom of tender sills aligned with mounting screw holes at front of tender shell. Fit the tender floor to the tender shell using more of the small screws from Amazon at the back of the tender shell, then mark or start holes at front using alignment marks. Remove tender shell from floor for final drilling of 1.5mm holes.



Drill or chase holes for handrails, whistle, air-pump and generator exhausts in 3D printed locomotive superstructure and tender shell.



Note: completed locomotive is VERY light and challenged.

Optional: cut and shape metal weights for locomotive boiler and rear of tender (or use tungsten putty) and attach as shown. Add a thin layer of cigarette paper over metal weights in boiler to insulate from the diecast chassis.



Nn3 Southern Pacific Narrow Gauge Locomotive #18

Add horizontal handrails to both locomotive and tender using Gold Medal Models handrail stanchions (from their Steam Locomotive Details etch) and .010"-.012" brass wire. Also add generator exhaust stack and handrails at rear edge of cab. Use annealed .010" brass wire to wrap around hard .010"-.012" brass wire to form whistle. Flow solder into wrapped assembly to form whistle body. Install in hole previously drilled in steam dome.

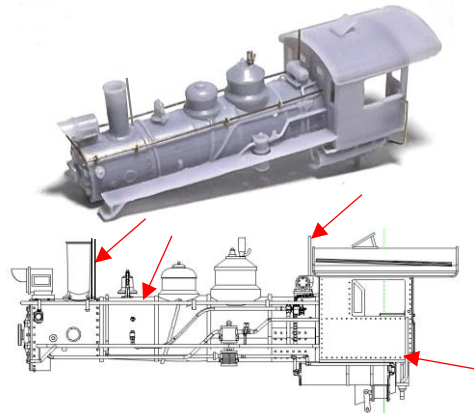

Using provided jig, form tender deck railings from .010" or .012" brass wire, then glue in place, using jig to set height above deck. Suggestion: form and install primary handrail first, then install intermediate vertical posts and solder or glue to primary railing. Make sure vertical posts do not extend into open interior of tender shell. Optional: form coupler cut bar from brass wire and install using two Gold Medal Models stanchions.

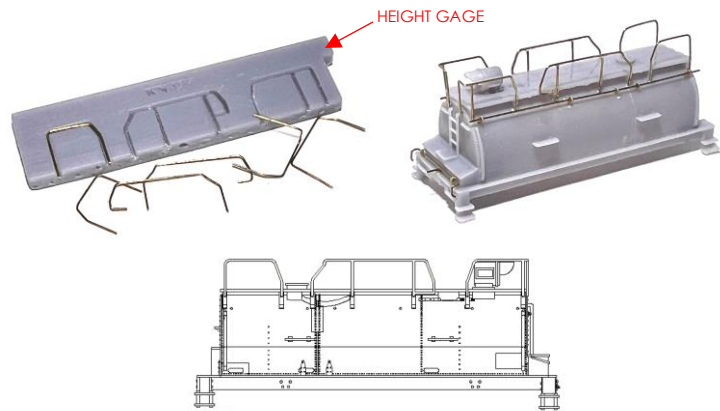

Airbrush locomotive superstructure and tender shell. Brush-paint pilot, cylinders, truck sideframes. Letter with Microscale Southern Pacific decal set #60-105. Add glazing to cab windows. Weather to suit. (Desert operations left a lot of alkali dust on the lower parts of the locomotive and tender.) Attach loco superstructure to chassis first fitting smokebox over locking tab, then pressing down cab until tabs lock under chassis. Fit tender shell over motor and tender floor and attach with four small screws; this is easier if trucks are removed for this step. If required, file edges of weight on top of motor so tender shell fits with side sills flush with bottom of Rokuhan floor.



Optional: brush paint backhead – see Carson & Colorado Railway web site for prototype restoration photos – then fit backhead into cab, sliding in sideways before turning and gluing in place aligning opening in backhead with opening in superstructure.

Optional: Add LaBell engineer & fireman.

Optional: Add pre-wired LEDs to front and back headlights after painting interior of headlight housings with Vallejo Aluminum paint (or equal), Add appropriate resistors in series with each LED. Front LED can attach to modified Rokuhan LED light board (with difficulty) for conventional DC operation, or wires can run to the tender if locomotive is equipped with DCC. To improve electrical pick-up, run wires from the locomotive chassis to the tender motor connections or decoder.